



Main

Range compatibility	Lexium 32i
Product or component type	Servo motor with power stage
Device short name	BMI

Complementary

Maximum mechanical speed	8000 rpm
[Us] rated supply voltage	208...480 V (- 15...10 %)
Supply voltage limits	208...480 V
Network number of phases	Three phase
Supply frequency	50/60 Hz (- 5...5 %)
Network frequency limits	47.5...63 Hz
EMC filter	Integrated
Continuous output current	2 A at 8 kHz
Output current 3s peak	6 A at 400 V for 3 s
Continuous stall current	2 A
Continuous stall torque	2.48 N.m at 208...480 V, three phase
Peak stall torque	6.8 N.m at 480 V, three phase 6.8 N.m at 400 V, three phase 6.8 N.m at 208 V, three phase
Nominal output power	900 W at 480 V, three phase 800 W at 400 V, three phase 400 W at 208 V, three phase
Nominal torque	2 N.m at 480 V, three phase 2.2 N.m at 400 V, three phase 2.4 N.m at 208 V, three phase
Nominal speed	4400 rpm at 480 V, three phase 3600 rpm at 400 V, three phase 1800 rpm at 208 V, three phase
Maximum current Irms	9.6 A at 480 V, three phase 9.6 A at 400 V, three phase 9.6 A at 208 V, three phase
Product compatibility	LXM32i drive control unit (EtherCAT) LXM32i drive control unit (CANopen)
Shaft end	Keyed
Second shaft	Without second shaft end
Shaft diameter	11 mm
Shaft length	23 mm
Key width	4 mm
Feedback type	Absolute multiturn SinCos Hiperface
Speed feedback resolution	32768 points/turn x 4096 turns
Holding brake	With

Holding torque	3 N.m for holding brake
Mounting support	International standard flange
Motor flange size	70 mm
Electrical connection	Printed circuit board connector
Torque constant	1.15 N.m/A at 20 °C
Back emf constant	77.18 V/krpm at 20 °C
Number of motor poles	10
Rotor inertia	1.24 kg.cm ²
Stator resistance	8.89 Ohm at 20 °C
Stator inductance	25.75 mH at 20 °C
Stator electrical time constant	2.9 ms at 20 °C
Maximum radial force Fr	390 N at 6000 rpm 410 N at 5000 rpm 450 N at 4000 rpm 490 N at 3000 rpm 560 N at 2000 rpm 710 N at 1000 rpm
Maximum axial force Fa	0.2 x Fr
Brake pull-in power	5 W
Type of cooling	Natural convection
Length	306 mm
Number of motor stacks	2
Centring collar diameter	60 mm
Centring collar depth	2.5 mm
Number of mounting holes	4
Mounting holes diameter	5.5 mm
Circle diameter of the mounting holes	75...82 mm
Distance shaft shoulder-flange	2.5 mm

Environment

IP degree of protection	IP65
-------------------------	------

Offer Sustainability

Sustainable offer status	Green Premium product
RoHS (date code: YYWW)	Compliant - since 1301 - Schneider Electric declaration of conformity
REACH	Reference not containing SVHC above the threshold
Product environmental profile	Available Download Product Environmental
Product end of life instructions	Available Download End Of Life Manual

External Dimensions

With Standard Braking Resistor

Mounting type A

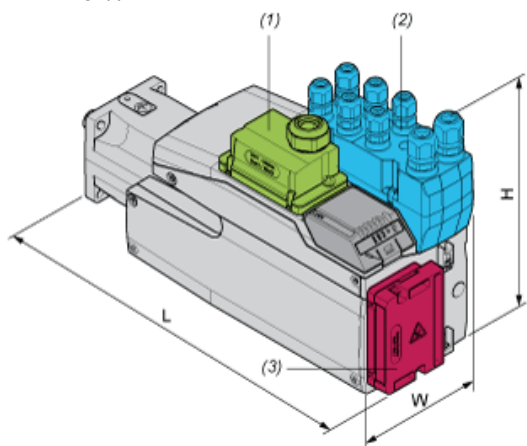

- (1) Module for supply voltage
- (2) I/O module
- (3) Standard braking resistor

Dimensions in mm

W	H	L
99	187	327

Dimensions in in.

W	H	L
3,90	7,36	12,87

Mounting type B

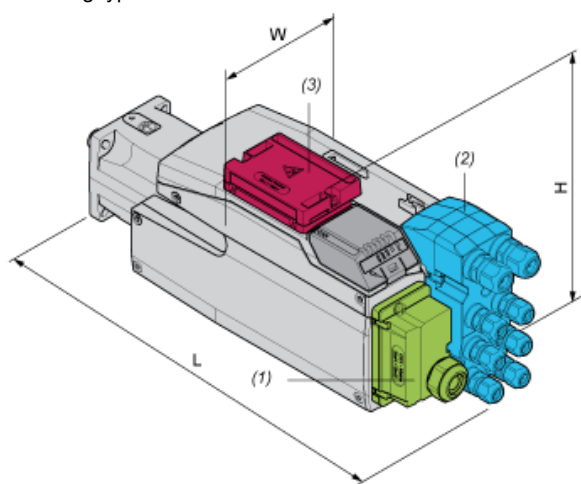

- (1) Module for supply voltage
- (2) I/O module
- (3) Standard braking resistor

Dimensions in mm

W	H	L
99	138,5	376

Dimensions in in.

W	H	L
3,90	5,45	14,8

With External Braking Resistor

Mounting type C



- (1) Module for supply voltage
- (2) I/O module
- (4) External braking resistor

Dimensions in mm

W	H	L
99	187	339

Dimensions in in.

W	H	L
3,90	7,36	13,35

Mounting type D



- (1) Module for supply voltage
- (2) I/O module
- (4) External braking resistor

Dimensions in mm

W	H	L
99	160	376

Dimensions in in.

W	H	L
3,90	6,3	14,8

Mounting type E



- (1) Module for supply voltage
- (2) I/O module
- (4) External braking resistor

Dimensions in mm

W	H	L
99	187	366

Dimensions in in.

W	H	L
3,90	7,36	14,41

Mounting type F



- (1) Module for supply voltage
- (2) I/O module
- (4) External braking resistor

Dimensions in mm

W	H	L
99	180	376

Dimensions in in.

W	H	L
3,90	7,09	14,8