

REV. 更改	DESCRIPTION 說明	ENG. 修改人	APPROVE 審核

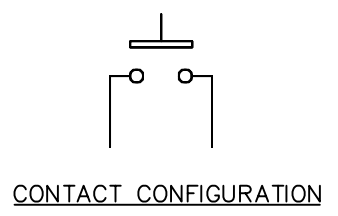
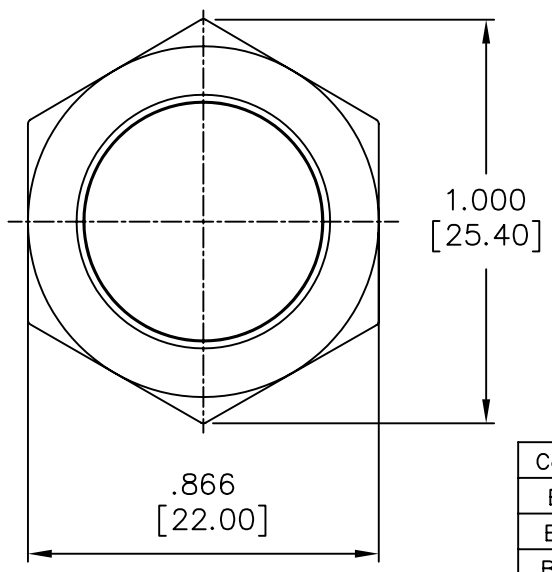
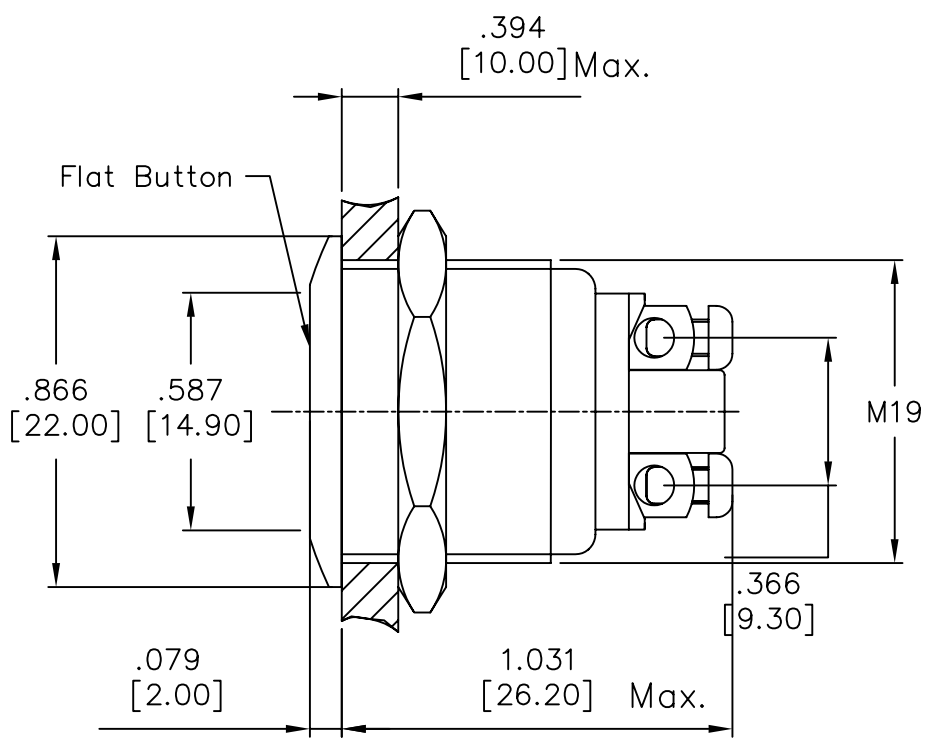

Code	Bushing & Button Material
B2	Nickel plated brass with varnished polished
B21	Gold plated brass with varnished polished
B22	Stainless steel with varnished polished

SPECIFICATIONS:

- Contact Rating: 2A @ 36VDC.
- Electrical Life: 200,000cycles.
- Contact Resistance: 50m-ohms max (initial).
- Insulation Resistance: 1,000M-ohms min @ 500VDC.
- Dielectric Strength: 2,000V RMS 50~60Hz.
- Operating Temperature: -20°C ~ +55°C.
- Switching Circuit: OFF-MOM.
- IP Class: IP65 protection.
- Torque: 5~14Nm max. applied to nut.
- Operating Force: 4N max.

MATERIALS:

- Bushing & Button: Refer to above table
- Contact: Silver alloy.
- Nut: Nickel plated brass.
- Base: PBT.

ITEM NO. 料號	AV01-B22-M1-F
----------------	---------------

THESE DRAWINGS AND SPECIFICATIONS ARE THE PROPERTY OF TAIWAY ELECTRONICS LTD. AND SHALL NOT BE REPRODUCED COPIED OR USED IN ANY MANNER WITHOUT THE PRIOR WRITTEN CONSENT OF TAIWAY ELECTRONICS LTD.

UNLESS OTHERWISE SPECIFIED DIMENSIONS ARE IN MILLIMETERS ANGULAR TOLERANCE: ±1.0°

DIMENSIONS	TOLERANCE
0.00 TO 30.00mm	±0.20mm
30.01 TO 80.00mm	±0.25mm
80.01 TO 150.00mm	±0.30mm
150.01	±0.40mm

泰瑋電子有限公司 TAIWAY ELECTRONICS COMPONENTS CO.,LTD.			
USED 用途	AV	APPD. 審核	Amy 2007/11/29
FINISH 處理		CHKD. 校對	Amy 2007/11/29
SCALE 比例	2 / 1	UNIT 單位	in(mm)
		DR. 製圖	Amy 2007/11/29

TITLE 名稱		Anti-Vandal Switch					
DWG NO. 圖號		AV01-B2(B2x)-M1-F				SIZE 圖紙	A4
FILE NAME 檔案名稱	AV01B2M1F.DWG	SHEET 張	1 / 1			REV. 更改	1