

# Fuji Molded Case Circuit Breakers – Field-mountable Accessories



## Defeatable Rotary Handle Operating Mechanisms

BW9V0CA shown

| Rotary Operating Handles for Fuji MCCBs – Selection Guide |               |       |                     |  |  |   |  |                |                             |
|---|---------------|-------|---------------------|--|--|---|--|----------------|-----------------------------|
| Breaker Type  | V-type Handle | Price | V-type Handle       | With the optional shaft (x= 6.102 (155)) |  | With the optional shaft (x= 24.567 (624)) |  | Mounting Screw | V-type Handle Mass lb. (kg) |
|   |               |       | H: inch(mm)         | Max. Mounting Depth H: inch(mm)          | Range in which the hinge with H can be installed | Max. Mounting Depth H: inch(mm)           | Range in which the hinge with H can be installed |                |                             |
| BW125   | BW9V0CA       | <---> | 4.134±0.078 (105±2) | 9.843±0.078 (250±2)                      | 5.512 to 9.843 (140 to 250)                      | 28.307±0.078 (719±2)                      | 28.307 - 5.591 (124 - 719)                       | M4 x 3.35 (85) | 1.48 (0.67)                 |
| BW250   | BW9V0GA       | <---> |                     |  |  |   |  |                |                             |

### Dimensions

Units: inches [mm]

- Notes:**
- Handle is an operating mechanism only; not for sealing enclosure door.
  - Not available for side mounting
  - For BW250 Series only: When mounting a terminal cover, cut away part of it because it hides the mounting screws for the breaker.

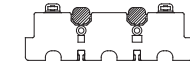

Remove the shaded parts in the figure.

125A, 250A Frame V type handle

- BW9V0CA, BW9V0GA (BW9VSG0, BW9VSG0-24: optional shafts)

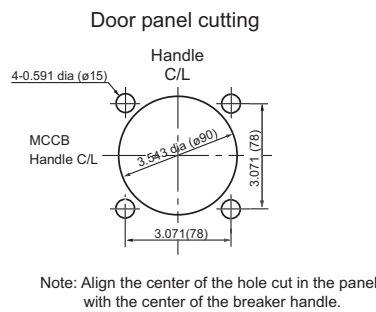
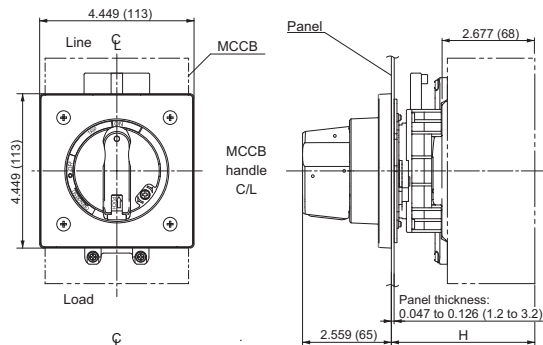

Note: Align the center of the hole cut in the panel with the center of the breaker handle.

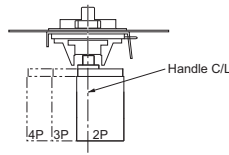

### Door hinge installation area

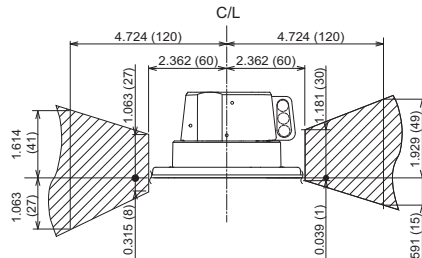

Install the door hinge in the shaded area.

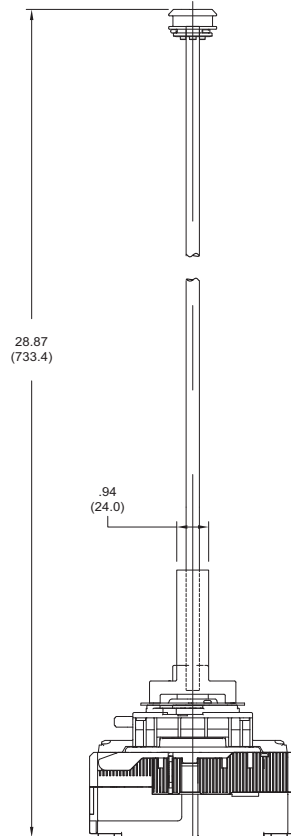

BW9VSG0-24 optional shaft Breaker and Shaft Assembly

**Optional shafts**  
BW9VSG0  
X = 6.102 (155)  
BW9VSG0-24  
X = 24.567 (624)

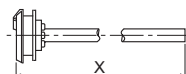

# Fuji Molded Case Circuit Breakers – Field-mountable Accessories



| Rotary Operating Handles for Fuji MCCBs – Selection Guide |               |       |                    |   |  |   |  |                |                             |
|---|---------------|-------|--------------------|---|--|---|--|----------------|-----------------------------|
| Breaker Type  | V-type Handle | Price | V-type Handle      | With the optional shaft (x= 3.504 (89)) |  | With the optional shaft (x= 24 (609.6)) |  | Mounting Screw | V-type Handle Mass lb. (kg) |
|   |               |       | H: inch(mm)        | Max. Mounting Depth H: inch(mm)         | Range in which the hinge with H can be installed | Max. Mounting Depth H: inch(mm)         | Range in which the hinge with H can be installed |                |                             |
| BW400   | BW9V0HA       | <---> | 7.48±0.078 (190±2) | 9.843±0.078 (250±2)                     | 7.95 to 9.843 (202to 250)                        | 30.35±0.078 (771±2)                     | 7.95 - 30.35 (202 - 771)                         | M4 x 3.35 (85) | 1.48 (0.67)                 |
| BW630<br>BW800  | BW9V0JA       | <---> |                    |   |  |   |  |                |                             |

- Notes:
- Handle is an operating mechanism only; not for sealing enclosure door.
  - Not available for side mounting

## Dimensions

Units: inches [mm]

### 400A, 630A, 800A Frame V type handle

- BW9V0HA, BW9V0JA (BZ-VS2, BZ-VS2-24: optional shafts)

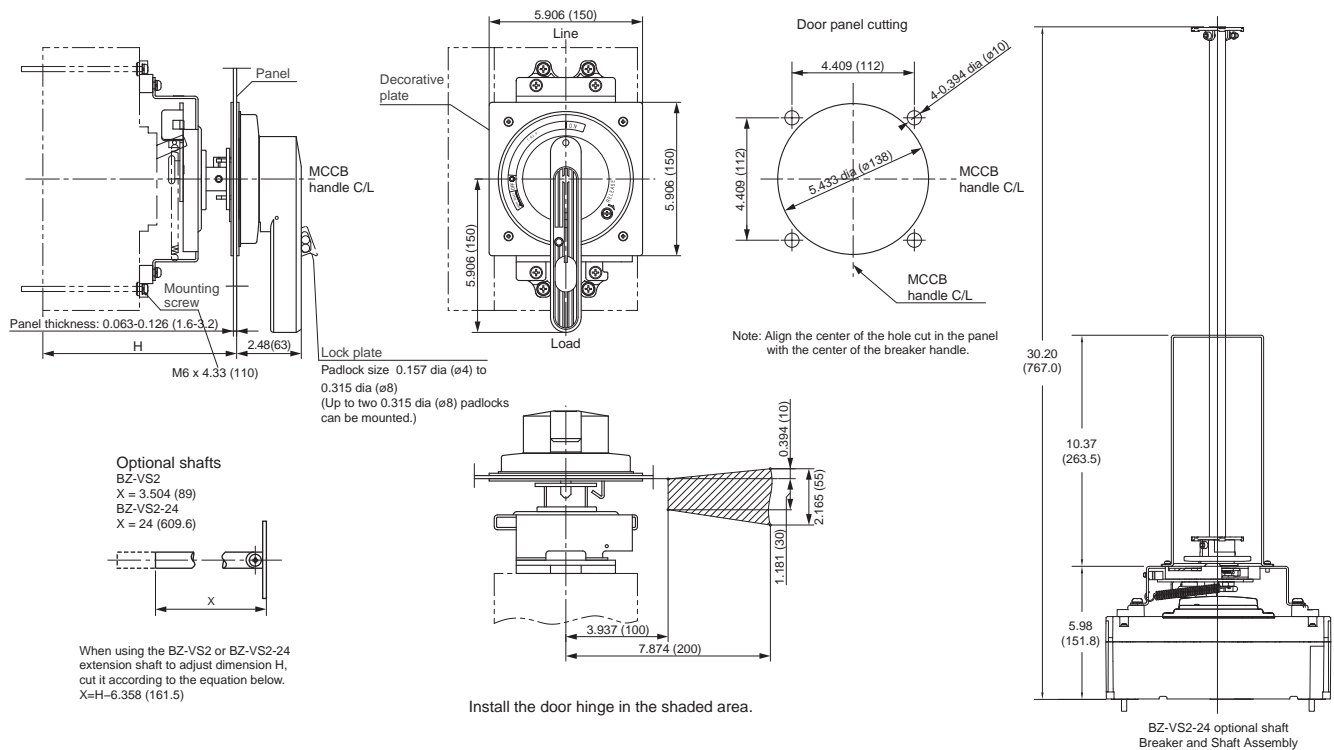

# Fuji Molded Case Circuit Breakers – Field-mountable Accessories

## Defeatable Flexible Handle Operating Mechanisms



BW9F0JA-20A shown

| Flex Shaft Handles for Fuji MCCBs – Selection Guide |             |       |  |
|---|-------------|-------|--|
| Breaker Type  | Handle Type | Price | Description  |
| BW125   | BW9F0CA-15A | <---> | Nema 12 flexible shaft handle for 125A frame. 59.06" (1.5m)cable         |
|   | BW9F0CA-20A | <---> | Nema 12 flexible shaft handle for 125A frame. 78.74" (2m) cable          |
| BW250   | BW9F0GA-15A | <---> | Nema 12 flexible shaft handle for 250A frame. 59.06" (1.5m)cable         |
|   | BW9F0GA-20A | <---> | Nema 12 flexible shaft handle for 250A frame. 78.74" (2m) cable          |
| BW400*  | BW9F0HA-15A | <---> | Nema 12 flexible shaft handle for 400A frame. 59.06" (1.5m)cable         |
|   | BW9F0HA-20A | <---> | Nema 12 flexible shaft handle for 400A frame. 78.74" (2m) cable          |
| BW630* & BW800*                                     | BW9F0JA-15A | <---> | Nema 12 flexible shaft handle for 630A or 800A frame. 59.06" (1.5m)cable |
|   | BW9F0JA-20A | <---> | Nema 12 flexible shaft handle for 630A or 800A frame. 78.74" (2m) cable  |

\*Terminal covers for line side and load side included with Flange Disconnects. 2/pk

| Flex Handle Specifications           |  |                   |                   |                       |
|--------------------------------------|--|-------------------|-------------------|-----------------------|
| <b>Operating instructions</b>        | <ul style="list-style-type: none"> <li>Operating handle facing up, Breaker is in ON position.</li> <li>Operating handle facing down, Breaker is in OFF position or is reset.</li> <li>Panel door cannot be opened when in ON, OFF or Trip position. In order to open the door, the handle must be turned toward reset position.</li> <li>Release screw is standard. If you want to open a panel door in ON position, please turn the release screw using flat head screwdriver.</li> </ul> |                   |                   |                       |
| <b>Frame Size</b>                    | <b>125A frame</b>  | <b>250A frame</b> | <b>400A frame</b> | <b>630A/800 frame</b> |
| <b>Mechanical Endurance (cycles)</b> | 10,000   | 8,000             | 6,000             | 6,000                 |
| <b>Ambient Temperature</b>           | 14 to 140F (- 10 to 40°C)  |                   |                   |                       |
| <b>Relative Humidity</b>             | less than 95% RH   |                   |                   |                       |
| <b>Protection</b>                    | NEMA Type12 IP54 (IEC60529)  |                   |                   |                       |
| <b>Conforming Standards</b>          | NFPA 79(2007), ANSI(Lockout), OSHA(1910.147, Lockout/tagout), UL489(cUL)   |                   |                   |                       |
| <b>Environment</b>                   | No excessive dust, smoke, corrosive gases, flammable gases, steam or salt.   |                   |                   |                       |

# Fuji Molded Case Circuit Breakers – Field-mountable Accessories

## Dimensions

Units: mm [inches]

### BW9F0CA

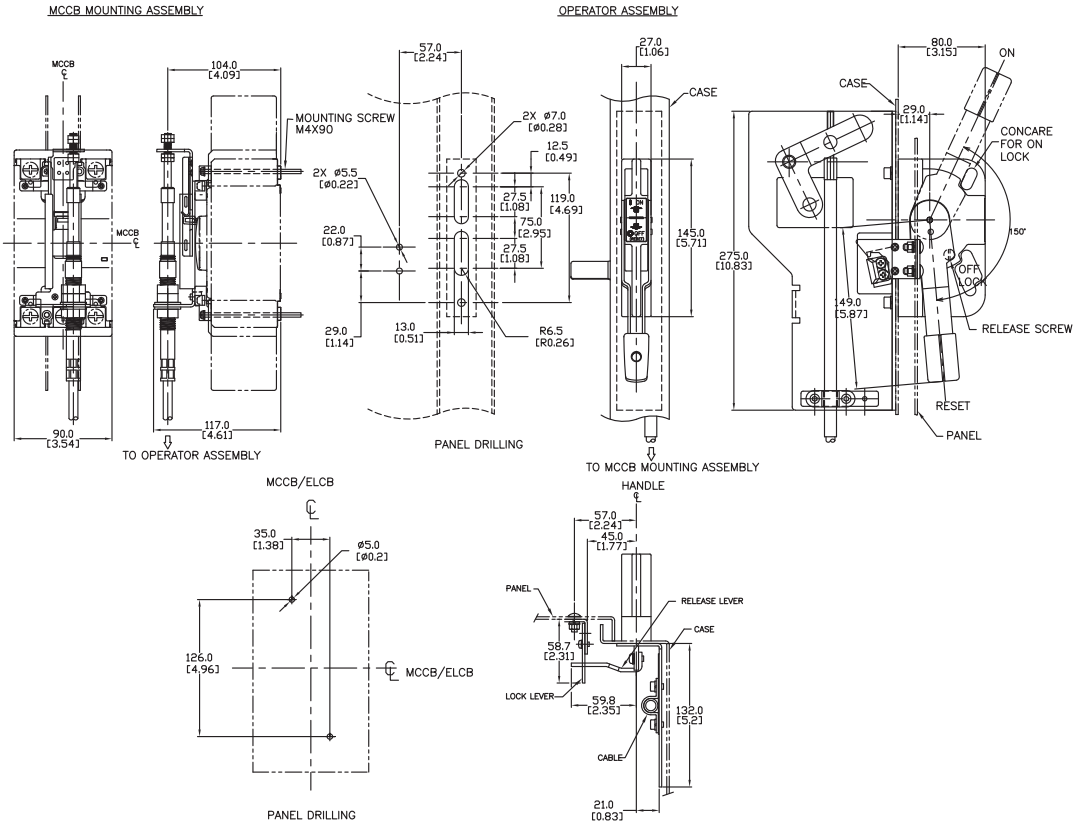

### BW9F0GA

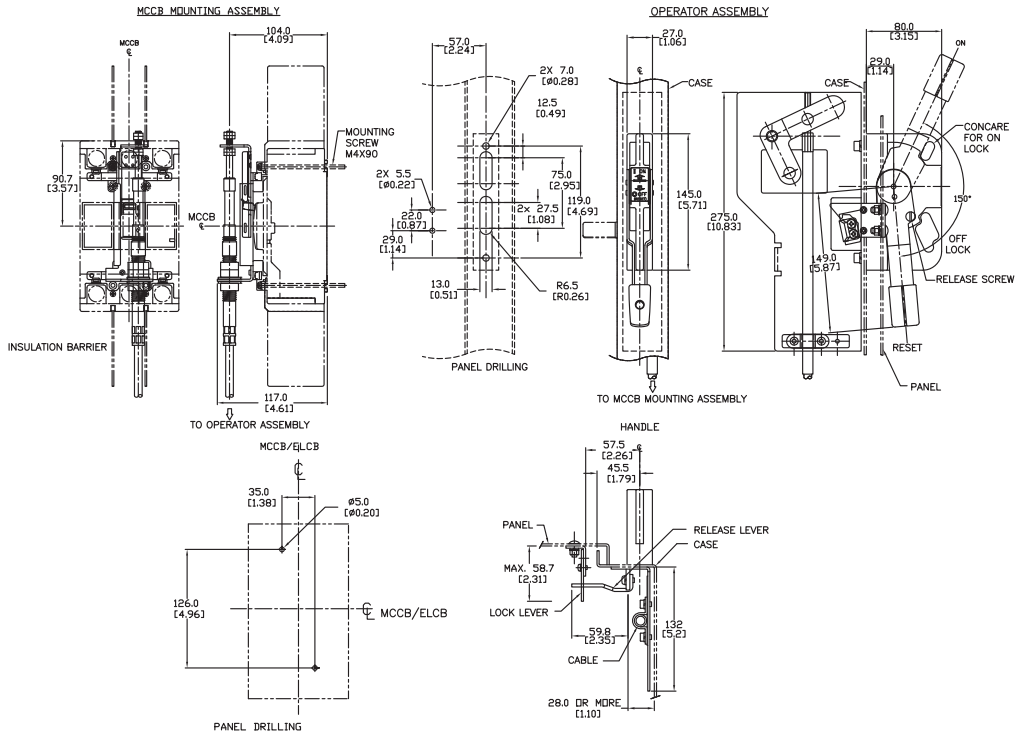

# Fuji Molded Case Circuit Breakers – Field-mountable Accessories

## Dimensions

Units: mm [inches]

### BW9F0HA

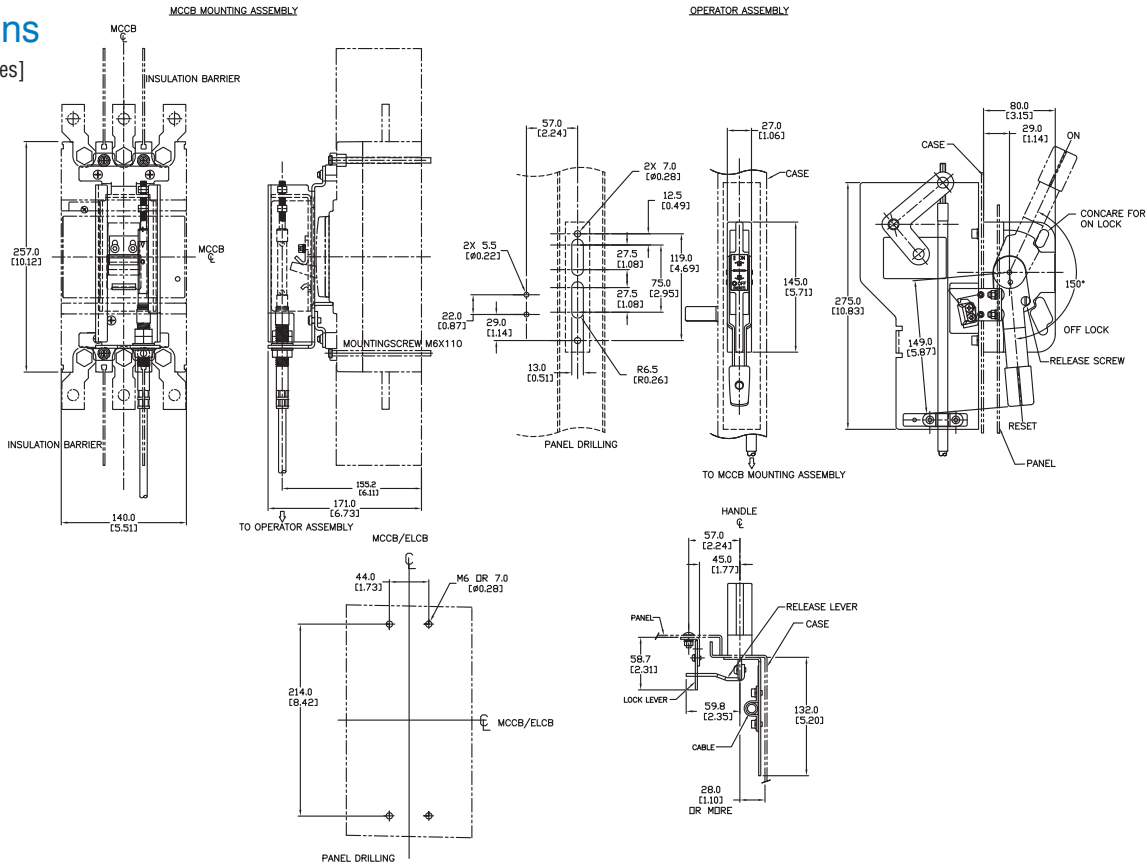

### BW9F0JA

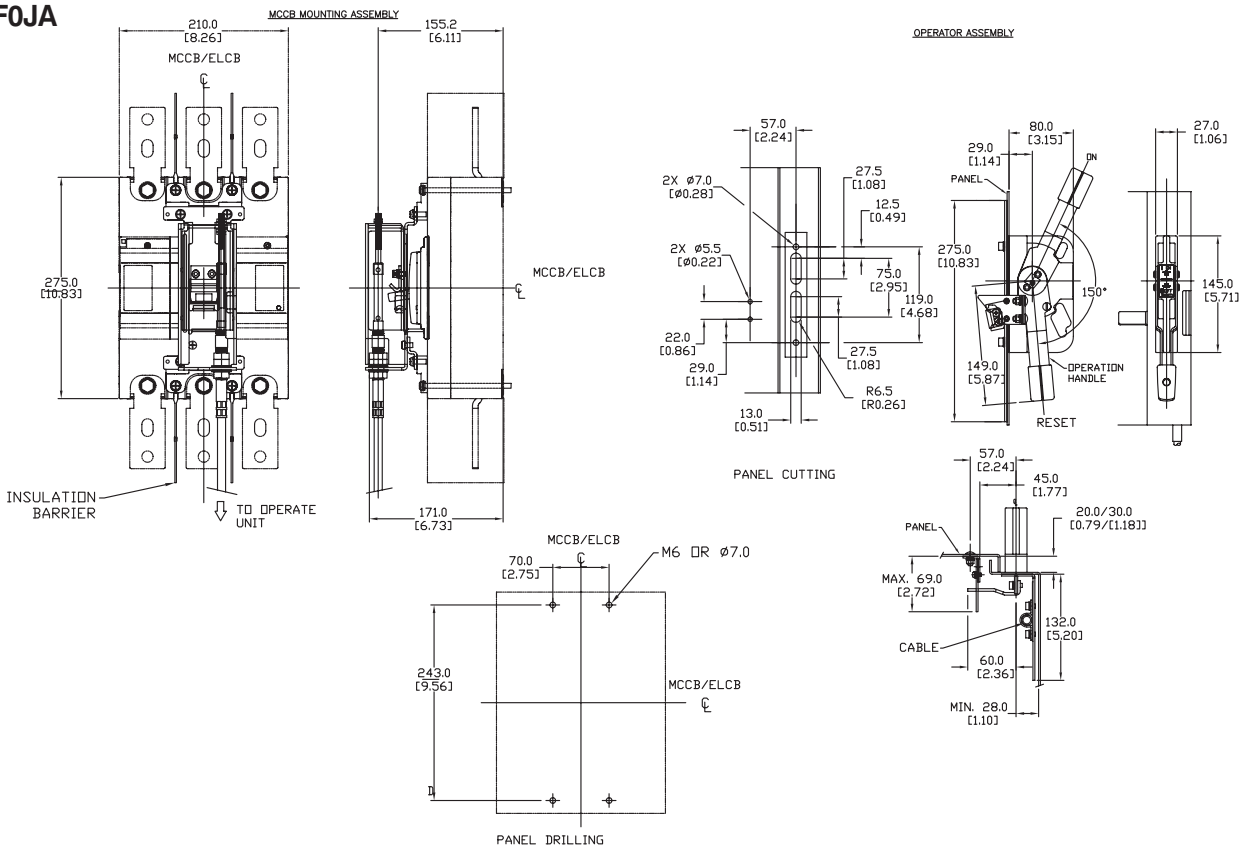

# Fuji Molded Case Circuit Breakers – Accessories



BW9W1SHA shown

## Auxiliary Contacts

The auxiliary contacts are accessory contacts for the indication of circuit breaker open-closed or tripped.

| Auxiliary Contacts for Fuji MCCBs – Selection Guide |             |       |  |
|---|-------------|-------|--|
| Breaker Type  | Part Number | Price | Description  |
| BW125<br>BW250                                      | BW9W1SGO    | <---> | Auxiliary switch for for 125A and 250A frame. Mounting left and right side   |
|   |             | <---> |  |
| BW400<br>BW630<br>BW800                             | BW9W1SHA    | <---> | Auxiliary switch for for 400A , 630A and 800A frame. Mounting left side ONLY |
|   |             | <---> |  |

| Ratings of Auxiliary Switches          |                           |                        |           |           |             |           |           |                      |
|--|---------------------------|------------------------|-----------|-----------|-------------|-----------|-----------|----------------------|
| Standard Type                          |                           |                        |           |           |             |           |           |                      |
| Breaker Type                           | Rated Thermal Current (A) | Make/Break Current (A) |           |           |             |           |           | Minimum Load Current |
|  |                           | AC                     |           |           | DC          |           |           |                      |
|  |                           | Voltage (V)            | Res. Load | Ind. Load | Voltage (V) | Res. Load | Ind. Load |                      |
| BW125,<br>BW250, BW400<br>BW630, BW800 | 5                         | 24                     | 5         | 5         | 24          | 4         | 3         | 5V DC 160 mA         |
|  |                           | 48                     | 5         | 5         | 48          | 2.5       | 1         | 30V DC 30 mA         |
|  |                           | 125                    | 5         | 3         | 125         | 0.4       | 0.4       |                      |
|  |                           | 250                    | 3         | 2         | 250         | 0.2       | 0.2       |                      |

### Operation of auxiliary switches

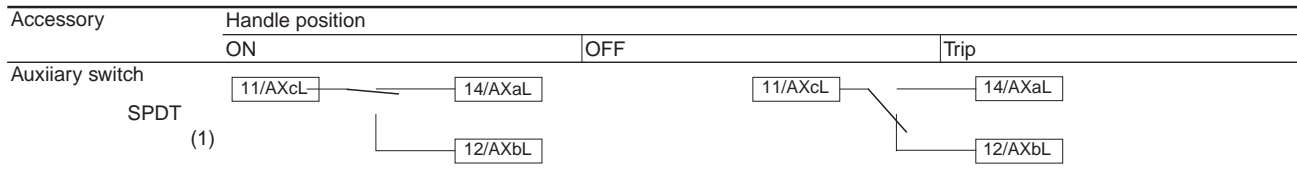

## Shunt Trips

Shunt Trip is for remote tripping (opening) of circuit breaker.



BW9FRG0 shown

| Shunt Trips for Fuji MCCBs – Selection Guide |       |   |
|--|-------|---|
| Part Number                                  | Price | Description   |
| BW9FRG0                                      | <---> | Field installable 24 VAC/VDC shunt trip for BW125 and BW250 series MCCB. Left and right side mounting. Lead wires 20AWG, 19.69" long.                 |
| BW9FHA-R                                     | <---> | Field installable 24/48 VAC/VDC shunt trip for BW400, BW630 and BW800 series MCCB. Left side mounting only. Lead wires 20AWG, 19.69" long.            |
| BW9FAG0                                      | <---> | Field installable 100/120 VAC, 100-110 VDC shunt trip for BW125 and BW250 series MCCB. Left and right side mounting. Lead wires 20AWG, 19.69" long.   |
| BW9FHA-A                                     | <---> | Field installable 100/240 VAC, 100-220 VDC shunt trip for BW400, BW630 and BW800 series MCCB. Left side mounting only. Lead wires 20AWG, 19.69" long. |

| Ratings of Shunt Trips |             |    |             |    |  |                     |
|------------------------|-------------|----|-------------|----|--|---------------------|
| Breaker Type           | AC          |    | DC          |    | Time Rating of Coil                                      | Operating Time (ms) |
|                        | Voltage (V) | VA | Voltage (V) | W  |  |                     |
| BW125, BW250           | 24          | 50 | 24          | 50 | Continuous (with 1 N.O. contact to prevent coil burnout) | 13-21               |
|                        | 100-120     | 50 | 100-110     | 50 |  |                     |
| BW400, BW630, BW800    | 24-48       | 2  | 24-48       | 2  | Continuous   | 8-20                |
|                        | 100-240     | 3  | 100-220     | 3  |  |                     |

Note: Allowable operating voltage AC voltage: 85% to 110% of coil rated voltage DC voltage: 75% to 125% of coil rated voltage

# Fuji Molded Case Circuit Breakers – Accessories



## Undervoltage Releases

Undervoltage Release will trip the circuit breaker when the connected voltage drops to less than 70% of undervoltage release voltage rating. It will allow the circuit breaker to close (ON) when voltage is approximately 85% of rated voltage.

| Undervoltage Releases for Fuji MCCBs – Selection Guide |             |       |  |  |
|--|-------------|-------|--|--|
| Breaker Type   | Part Number | Price | Description  |  |
| BW125, BW250   | BW9RGAR     | <-->  | Undervoltage Release 24V DC (Left side ONLY)                 |  |
| BW125, BW250   | BW9RGAT     | <-->  | Undervoltage Release 110 to 130 VAC VAC/VDC (Left side ONLY) |  |
| BW400, BW630, BW800                                    | BW9RHA-R    | <-->  | Undervoltage Release 24 VAC/VDC (Left side ONLY)             |  |
| BW400, BW630, BW800                                    | BW9RHA-1    | <-->  | Undervoltage Release 120 to 130 VAC 125 VDC (Left side ONLY) |  |



BW9RGAR shown

| Breaker Type                  | AC          |    | DC          |   |
|-------------------------------|-------------|----|-------------|---|
|                               | Voltage (V) | VA | Voltage (V) | W |
| BW125*1<br>BW250*1            | –           | –  | 24          | 5 |
|                               | 110 - 130   | 5  | –           | – |
| BW400*2<br>BW630*2<br>BW800*2 | 24          | 2  | 24          | 2 |
|                               | 120 - 130   | 3  | 125         | 3 |

Note: Allowable operating voltage: AC voltage: 85% to 110% of coil rated voltage  
DC voltage: 75% to 125% of coil rated voltage.

\*1 Reset-allowed type: When the breaker handle is in the OFF or RESET state, tripping does not occur, even if the undervoltage trip coil is not energized.  
Turning ON with the undervoltage trip coil not energized causes normal tripping.

\*2 Reset-prohibited type: When the undervoltage trip coil is not energized, reset operation cannot reset the tripped breaker to the OFF state.



BW9SL0GA-3 shown

## Replacement Lugs

| Replacement Lug Kits for Fuji MCCBs – Selection Guide |       |   |
|---|-------|---|
| Part Number   | Price | Description   |
| BW9SLOCA-3  | <-->  | Replacement lug kit for BW125 series MCCB. 75°C. Cu only<br>Package of 3              |
| BW9SLOGA-3  | <-->  | Replacement lug kit for BW250 series up to 175A MCCB. 75°C. Cu only<br>Package of 3   |
| BW9SL1GA-3  | <-->  | Replacement lug kit for BW250 MCCB series 200A to 250A. 75°C. Cu only<br>Package of 3 |

# Fuji Molded Case Circuit Breakers – Accessories



## Terminal Covers

Terminal covers act as guards to shield the operator from touching live terminations. They fit either the line or load side.



**BW9BTHA-L3W** shown

| Terminal Covers for Fuji MCCBs – Selection Guide |                    |       |   |                      |             |            |
|--|--------------------|-------|---|----------------------|-------------|------------|
| Breaker Series                                   | Part Number        | Price | Description   | Dimensions inch (mm) |             |            |
|  |                    |       |   | A                    | B           | C          |
| BW400  | <b>BW9BTHA-L3W</b> | <---> | Gray-white Long type terminal cover for Fuji MCCBs. For line side and load side. 2/pk | 6.772 (172)          | 4.331 (110) | 3.858 (98) |
| BW630, BW800                                     | <b>BW9BTJA-L3W</b> | <---> | Gray-white Long type terminal cover for Fuji MCCBs. For line side and load side. 2/pk | 8.268 (210)          | 6.102 (155) | 3.858 (98) |

*Note: Gray-white short type terminal covers are provided with breakers as standard for 125 and 250 Amp frames.*

Dimensions of Terminal Covers: inch (mm)

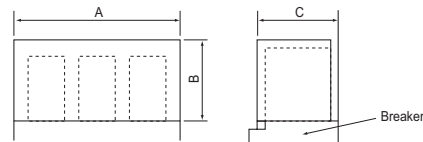

## Lockout Attachment

| Lockout Attachments for Fuji MCCBs – Selection Guide |                |       |   |
|--|----------------|-------|---|
| Breaker Series                                       | Part Number    | Price | Description   |
| BW125<br>BW250                                       | <b>BW9Q1CA</b> | <---> | Use to lock out BW125 and BW 250 series MCCBs.<br>Lock not included |
| BW400, BW630, BW800                                  | <b>BW9QNHA</b> | <---> | Use to lock out BW400, BW600 and BW800 MCCBs.<br>Lock not included. |



**BW9Q1CA** shown