

**RoHS** **Pb** **215SP Series, 5x20 mm, Time-Lag Fuse (Slo-Blo®)**

**Description**

5x20mm Time-Lag surge withstanding ceramic body cartridge fuse designed to IEC specification

**Features**

- Designed to International (IEC) Standards for use globally
- Meets the IEC 60127-2, Sheet 5 specification for Time-Lag Fuses
- RoHS compliant and Pb-free

**Applications**

Used as supplementary protection in appliance or utilization equipment to provide individual protection for components or internal circuits.

**Agency Approvals**

Agency	Agency File Number	Ampere Range
	Certificate No. Leaded NBK080205-E10480B NBK250702-E10480F	1A – 5A 6.3A – 10A
	Certificate No. CQC10012041490	1A – 6.3A
	Certificate No. SU05001-2011B SU05001-10001 SU05001-10002	1A – 2.5A 3.15A – 6.3A 8A
	Recognised File No. Guide No. E10480 JDYX2	1A – 10A
	File No. Acc. Class No. 029862 LR1422-30	1A – 10A
	Licence. No. 40013521	1 – 8A
		1A – 10A

**Electrical Characteristics for Series**

% of Ampere Rating	Ampere Rating	Opening Time
210%	1A - 3.15A	30 minutes, Maximum
	4A - 6.3A	30 minutes, Maximum
	8A - 10A	30 minutes, Maximum
275%	1A - 3.15A	.75 sec. Min.; 80 secs. Max.
	4A - 6.3A	.75 sec. Min.; 80 secs. Max.
	8A - 10A	.75 sec. Min.; 80 secs. Max.
400%	1A - 3.15A	.095 sec. Min.; 5 secs. Max.
	4A - 6.3A	.150 sec. Min.; 5 secs. Max.
	8A - 10A	.150 sec. Min.; 5 secs. Max.
1000%	1A - 3.15A	.010 sec. Min.; .150 secs. Max.
	4A - 6.3A	.010 sec. Min.; .150 secs. Max.
	8A - 10A	.010 sec. Min.; .150 secs. Max.

**Electrical Characteristic Specifications by Item**

Amp Code	Amp Rating	Voltage Rating	Interrupting Rating	Nominal Resistance Cold Ohms (Ohms)	Nominal Melting I <sup>2</sup> t (A <sup>2</sup> sec)	Maximum Voltage Drop at Rated Current (mV)	Maximum Power Dissipation at 1.5I <sub>n</sub> (W)	Agency Approvals						
001	1	250	1500 A @ 250 VAC	0.1515	1.52000	350	2.5	x	x	x	x	x	x	x
1.25	1.25	250		0.1074	3.20000	300	2.5	x	x	x	x	x	x	x
01.6	1.6	250		0.0707	6.83000	200	2.5	x	x	x	x	x	x	x
002	2	250		0.0566	11.68000	190	2.5	x	x	x	x	x	x	x
02.5	2.5	250		0.0386	22.29000	180	2.5	x	x	x	x	x	x	x
3.15	3.15	250		0.0283	43.25500	140	4	x	x	x	x	x	x	x
004	4	250		0.0185	46.96000	100	4	x	x	x	x	x	x	x
005	5	250		0.0153	66.09500	100	4	x	x	x	x	x	x	x
06.3	6.3	250		0.0108	128.75000	100	4	x	x	x	x	x	x	x
008	8	250		0.0092	209.88000	100	4	x		x	x	x	x	x
010	10	250		0.0066	333.56500	100	4	x			x	x		x

I<sup>2</sup>t test at 10x rated current

© 2012 Littelfuse, Inc.

Specifications are subject to change without notice. Please refer to [www.littelfuse.com/series/215SP.html](http://www.littelfuse.com/series/215SP.html) for current information.

Revised: September 19, 2012

215SP Series

215SP Series

## Temperature Derating Curve

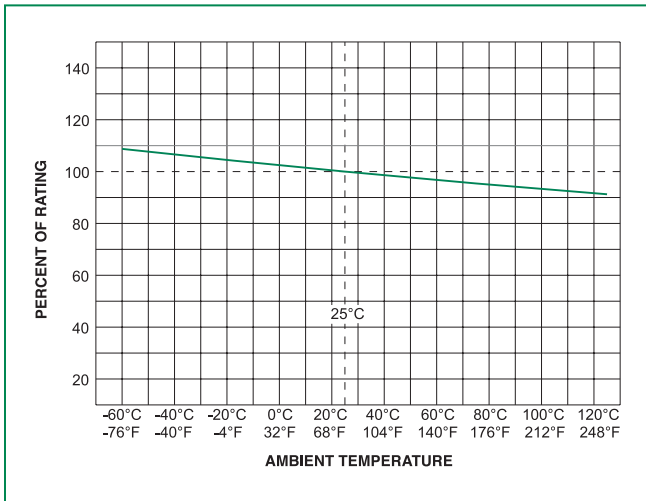

## Average Time Current Curves

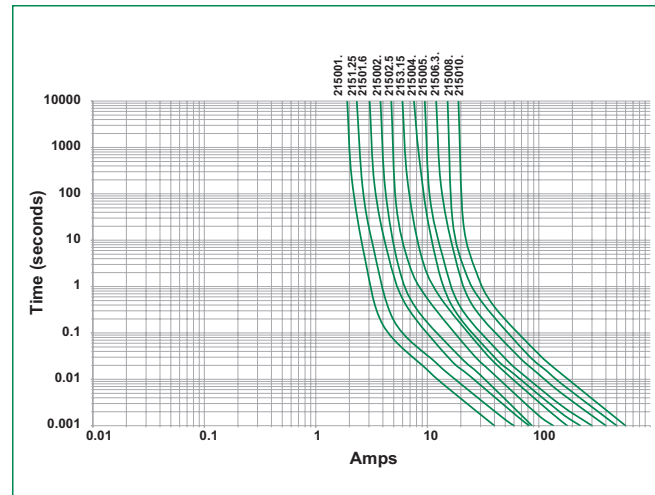

## Soldering Parameters - Wave Soldering

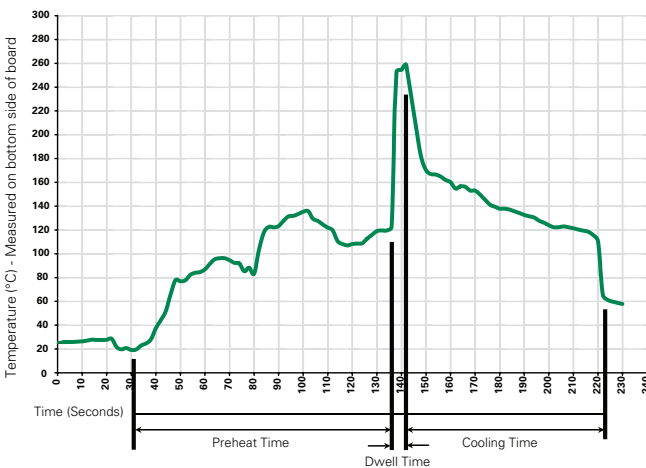

### Recommended Process Parameters:

Wave Parameter	Lead-Free Recommendation
<b>Preheat:</b> (Depends on Flux Activation Temperature)	(Typical Industry Recommendation)
Temperature Minimum:	100° C
Temperature Maximum:	150° C
Preheat Time:	60-180 seconds
<b>Solder Pot Temperature:</b>	260° C Maximum
<b>Solder Dwell Time:</b>	2-5 seconds

### Recommended Hand-Solder Parameters:

Solder Iron Temperature: 350° C +/- 5°C  
Heating Time: 5 seconds max.

**Note: These devices are not recommended for IR or Convection Reflow process.**

Different values of A and B available, please contact the Littelfuse sales representative in your region:

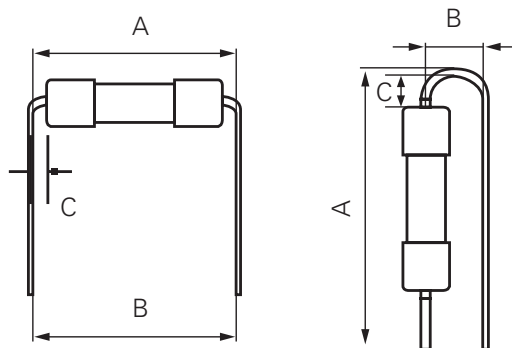

For the pigtailed fuse, please follow the recommendations below for axial lead forming and mounting into PCB:

### Lead forming:

The distance C between cap flat surface and axial lead shall be greater than 1.0 mm.

### PCB mounting:

According to the standard of IPC-A-610, the distance between PCB and fuse cap is recommended to be a minimum of 1.5 mm.

### Product Characteristics

<b>Materials</b>	<b>Body:</b> Ceramic <b>Cap:</b> Nickel-plated Brass <b>Leads:</b> Tin-plated Copper
<b>Terminal Strength</b>	MIL-STD-202G, Method 211A, Test Condition A
<b>Solderability</b>	Reference IEC 60127 Second Edition 2003-01 Annex A
<b>Product Marking</b>	<b>Cap 1:</b> Brand logo, current and voltage ratings <b>Cap 2:</b> Agency approval marks

<b>Operating Temperature</b>	-55°C to +125°C
<b>Thermal Shock</b>	MIL-STD-202G, Method 107G, Test Condition B (5 cycles, -65°C to +125°C)
<b>Vibration</b>	MIL-STD-202G, Method 201A
<b>Humidity</b>	MIL-STD-202G, Method 103B, Test Condition A (High RH (95%) and elevated temp (40°C) for 240 hours)
<b>Salt Spray</b>	MIL-STD-202G, Method 101D, Test Condition B

### Dimensions

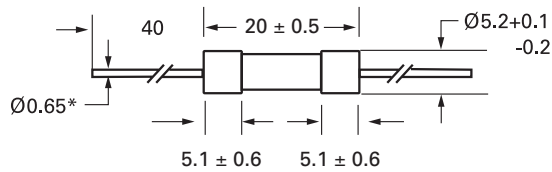

\* 8A and 10A have 0.8mm diameter  
 All unit in mm.

### Part Numbering System

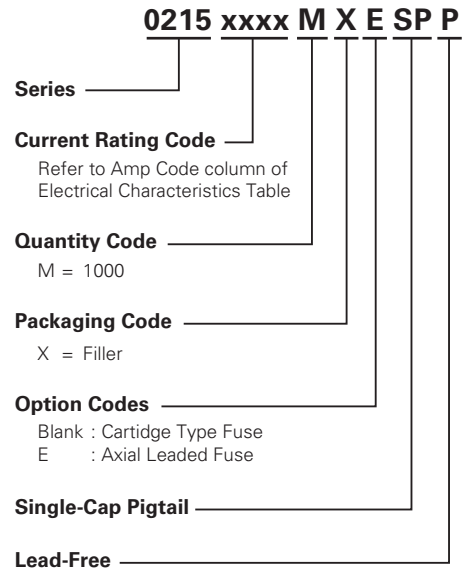

### Packaging

Packaging Option	Packaging Specification	Quantity	Packaging Code	Reel Size
<b>215SP Series</b>				
Bulk	N/A	1000	MXE	N/A