

●Features

- 1) Can be mounted even more densely than chip resistors.
- 2) Mounting cost can be reduced by less frequency of mounting times.
- 3) Convex electrodes secures visual inspection of fillets after soldering.
- 4) ROHM resistors have obtained ISO9001 / ISO / TS16949 certification.

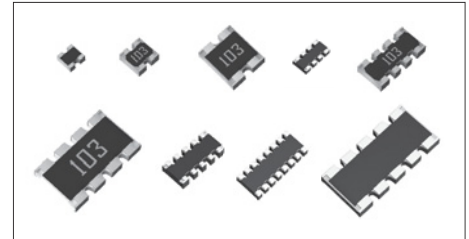

Part No.	Size		No. of terminals	No. of elements	Type Code	Packing Specification	Quantity / Reel	Automotive Grade Available
	(mm)	(inch)						
MNR02	1005 × 2	0402 × 2	4	2	M0AP	Paper tape (2mm Pitch)	10,000	Yes
MNR04	1005 × 4	0402 × 4	8	4	M0AP			
MNR12	1608 × 2	0603 × 2	4	2	E0AP	Paper tape (4mm Pitch)	5,000	
MNR14	1608 × 4	0603 × 4	8	4	E0AP			
MNR15	1608 × 5	0603 × 5	10	8	E0RP			
MNR18	1605 × 8	0602 × 8	16	8	E0AP			
MNR32	3216 × 2	1206 × 2	4	2	J0AB	Embossed tape (4mm Pitch)	4,000	
MNR34	3216 × 4	1206 × 4	8	4	J5AB			
MNR35	3216 × 5	1206 × 5	10	8	J5R			

●Part Number Description

M N R	0 2	M 0 A P	J	1 0 5						
Part No. MNR (Chip Resistor Networks)	Size (mm [inch]) 02 (1005 [0402] × 2) 04 (1005 [0402] × 4) 12 (1608 [0603] × 2) 14 (1608 [0603] × 4) 15 (1608 [0603] × 5) 18 (1605 [0602] × 8) 32 (3216 [1206] × 2) 34 (3216 [1206] × 4) 35 (3216 [1206] × 5)	Type Code	Resistance Tolerance F (±1%) J (±5%)(Including jumper type)	Nominal Resistance Resistance code, 3 or 4 digits. 000 denotes jumper type. <table border="1" style="width: 100%; margin-top: 5px;"> <thead> <tr> <th>Resistance tolerance</th> <th>Resistance code</th> </tr> </thead> <tbody> <tr> <td style="text-align: center;">F</td> <td style="text-align: center;">: 4 digits</td> </tr> <tr> <td style="text-align: center;">J</td> <td style="text-align: center;">: 3 digits</td> </tr> </tbody> </table> <p>Ex.)</p> 1Ω = 1R0 (±5%) 9.1Ω = 9R1 (±5%) 10Ω = 10R0 (±1%) 100 (±5%) 1MΩ = 1004 (±1%) 105 (±5%)	Resistance tolerance	Resistance code	F	: 4 digits	J	: 3 digits
Resistance tolerance	Resistance code									
F	: 4 digits									
J	: 3 digits									

●Products List

Part No.	Type Code	Rated Power (70°C) (W)	Limiting Element Voltage (V)	Temperature Coefficient (ppm / °C)	Resistance Tolerance (%)	Resistance Range	Series	Operating Temperature Range (°C)
MNR02	M0AP	0.063 / Element	25	±200	J(±5%)	10Ω to 1MΩ	E24	-55 to +155
MNR04	M0AP	0.063 / Element	25	+500/-250	J(±5%)	1Ω to 9.1Ω	E24	
				±200		10Ω to 1MΩ		
Jumper type : Rmax = 50mΩ / Imax. = 1A (Element)								
MNR12	E0AP	0.063 / Element	50	±200	J(±5%)	10Ω to 1MΩ	E24	
				±100	F(±1%)	10Ω to 1MΩ		
Jumper type : Rmax = 50mΩ / Imax. = 1A (Element)								
MNR14	E0AP	0.063 / Element	50	±500	J(±5%)	2.2Ω to 6.8Ω	E6	
				±200		10Ω to 1MΩ	E24	
				±100	F(±1%)	10Ω to 1MΩ		
Jumper type : Rmax = 50mΩ / Imax. = 1A (Element)								
MNR15	E0RP	0.031 / Element	12.5	±200	J(±5%)	56Ω to 100kΩ	E24	-55 to +125
MNR18	E0AP	0.063 / Element	25	±200	J(±5%)	10Ω to 1MΩ	E24	
MNR32	J0AB	0.125 / Element	200	±200	J(±5%)	10Ω to 1MΩ	E24	
								Jumper type : Rmax = 50mΩx / Imax. = 2A (Element)
MNR34	J5AB	0.125 / Element	200	±200	J(±5%)	10Ω to 1MΩ	E24	
								Jumper type : Rmax = 50mΩ / Imax. = 2A (Element)
MNR35	J5R	0.063 / Element	50	±200	J(±5%)	56Ω to 100kΩ	E12	

*Design and specifications are subject to change without notice. Carefully check the specification sheet supplied with the product before using or ordering it.

●Circuit Construction

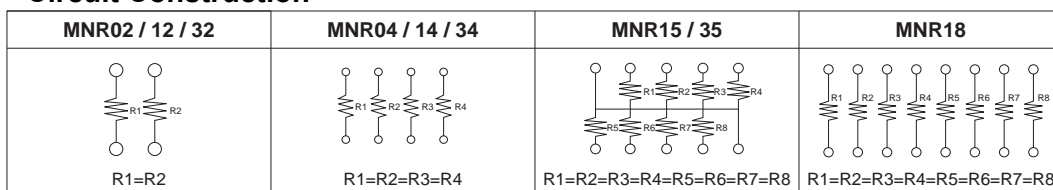

●Chip Resistor Dimensions and Markings

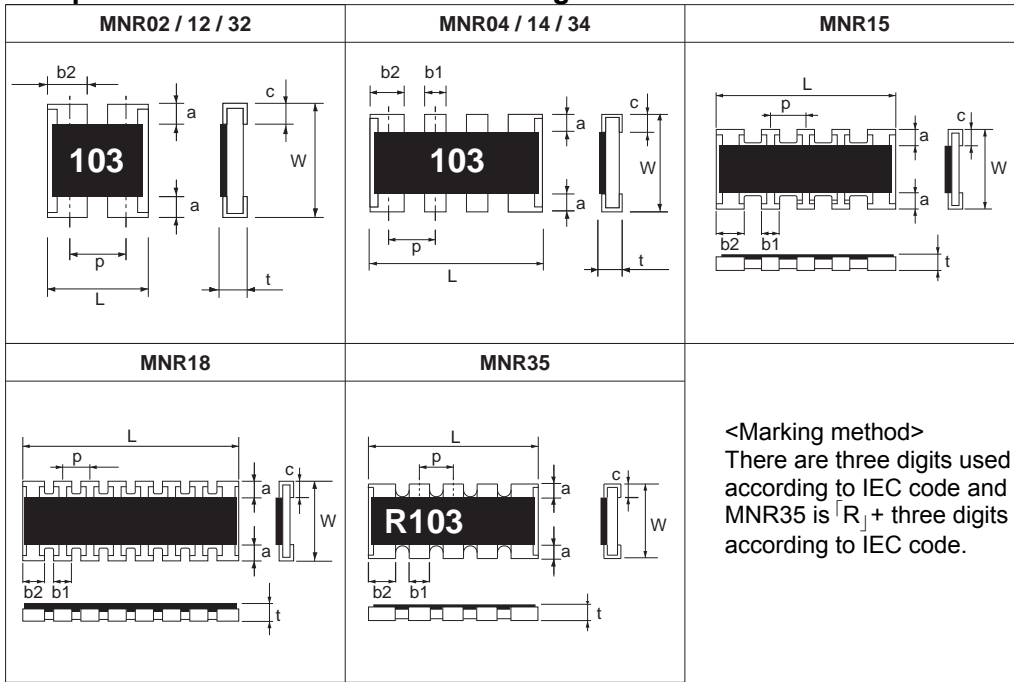

<Marking method>
 There are three digits used for the calculation number according to IEC code and "R" is used for the decimal point. MNR35 is "R" + three digits used for the calculation number according to IEC code.

(Unit : mm)

Part No.	Type Code	(mm)	(inch)	L	W	t	a	b1	b2	c	p	Marking existence *Including jumper type
MNR02	M0AP	1005 × 2	0402 × 2	1.0±0.1	1.0±0.1	0.35±0.1	0.2±0.1	—	0.33 ^{+0.1} ₀	0.25±0.1	0.68	No
MNR04	M0AP	1005 × 4	0402 × 4	2.0±0.1	1.0±0.1	0.35±0.1	0.2±0.1	0.3±0.1	0.4±0.1	0.25±0.1	0.5	No
MNR12	E0AP	1608 × 2	0603 × 2	1.6±0.1	1.6±0.1	0.5±0.1	0.3±0.2	—	0.6±0.15	0.25±0.15	0.8	Yes
MNR14	E0AP	1608 × 4	0603 × 4	3.2±0.1	1.6±0.1	0.5±0.1	0.3±0.2	0.4±0.15	0.6±0.15	0.25±0.15	0.8	Yes
MNR15	E0RP	1608 × 5	0603 × 5	3.2±0.1	1.6±0.1	0.5±0.1	0.3±0.1	0.32±0.15	0.48±0.15	0.3±0.1	0.64	No
MNR18	E0AP	1605 × 8	0602 × 8	3.8±0.1	1.6±0.1	0.45±0.1	0.3±0.2	0.3±0.1	0.3±0.1	0.3±0.2	0.5	No
MNR32	J0AB	3216 × 2	1206 × 2	2.6±0.2	3.1±0.2	0.55±0.1	0.5±0.3	—	1.0±0.2	0.5Max	1.27	Yes
MNR34	J5AB	3216 × 4	1206 × 4	5.2±0.4	3.1±0.2	0.55±0.1	0.5±0.3	0.8±0.2	1.0±0.2	0.5Max	1.27	Yes
MNR35	J5R	3216 × 5	1206 × 5	6.4±0.4	3.1±0.2	0.55±0.1	0.5±0.3	0.8±0.2	1.0±0.2	0.5Max	1.27	Yes

●Land pattern Example

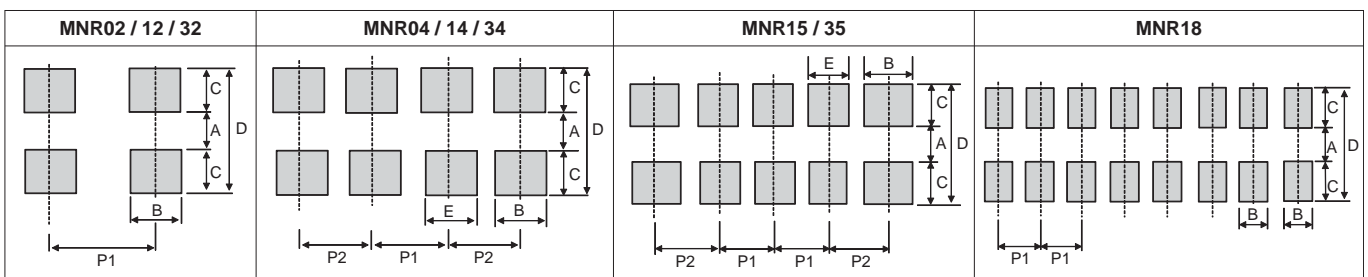

(Unit : mm)

Part No.	Dimensions Type Code	A	B	C	D	E	P1	P2
MNR02	M0AP	0.5	0.35 to 0.4	0.5	1.5	—	0.65 to 0.7	—
MNR04	M0AP	0.5	0.4	0.5	1.5	0.3	0.5	0.5 to 0.55
MNR12	E0AP	1.0	0.4 to 0.6	0.7 to 0.8	2.4 to 2.6	—	0.8 to 1.0	—
MNR14	E0AP	1.0	0.4 to 0.6	0.7 to 0.8	2.4 to 2.6	0.4	0.8	0.8 to 0.9
MNR15	E0RP	1.0	0.48	0.7 to 0.8	2.4 to 2.6	0.32	0.64	0.72
MNR18	E0AP	1.0	0.3	0.7 to 0.8	2.4 to 2.6	—	0.5	—
MNR32	J0AB	2.1	0.8 to 1.0	0.8 to 1.0	3.7 to 4.1	—	1.27 to 1.6	—
MNR34	J5AB	2.1	0.8 to 1.0	0.8 to 1.0	3.7 to 4.1	0.7 to 0.8	1.27 to 1.35	1.27 to 1.45
MNR35	J5R	2.1	0.8 to 1.0	0.8 to 1.0	3.7 to 4.1	0.7 to 0.8	1.27 to 1.3	1.27 to 1.4

●Derating Curve

When the ambient temperature exceeds 70°C, power dissipation must be adjusted according to the derating curves below.

■ MNR02 / 04 / 12 / 14

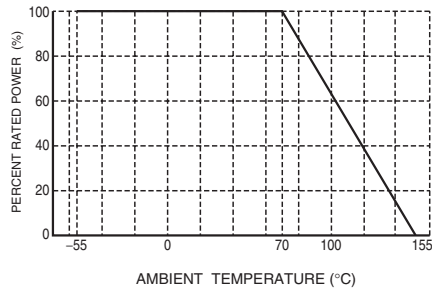

■ MNR15 / 18 / 32 / 34 / 35

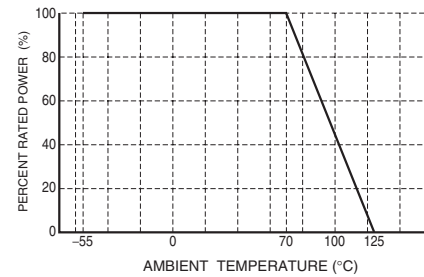

●Characteristics

Test Items	Guaranteed Value		Test Conditions
	Resistor Type	Jumper Type	
Resistance	See "Products List"		20°C
Variation of resistance with temperature	See "Products List"		Measurement : +20 / -55 / +20 / +125°C
Overload	± (2.0%+0.1Ω)	Max. 50mΩ	Rated voltage (current) ×2.5, 2s. Maximum overload voltage
Solderability	A new uniform coating of minimum of 95% of the surface being immersed and no soldering damage.		Rosin-Ethanol : 25% (weight) Soldering condition : 235±5°C Duration of immersion : 2.0±0.5s
Resistance to soldering heat	± (1.0%+0.05Ω) ± (1.0%+0.1Ω)※MNR35 No remarkable abnormality on the appearance.	Max. 50mΩ	Soldering condition : 260±5°C Duration of immersion : 10±1s
Rapid change of temperature	± (1.0%+0.05Ω) ± (1.0%+0.1Ω)※MNR35	Max. 50mΩ	Test temp. : -55°C to +125°C 5cycle
Damp heat, steady state	± (3.0%+0.1Ω)	Max. 100mΩ	40°C, 93%RH (Relative Humidity) Test time : 1,000h to 1,048h
Endurance at 70°C	± (3.0%+0.1Ω)	Max. 100mΩ	70°C Rated voltage (current) 1.5h : ON – 0.5h : OFF Test time : 1,000h to 1,048h
Endurance	± (3.0%+0.1Ω)	Max. 100mΩ	155°C (MNR02 / 04 / 12 / 14) 125°C (MNR15 / 18 / 32 / 34 / 35) Test time : 1,000h to 1,048h
Resistance to solvent	± (1.0%+0.05Ω) ± (1.0%+0.1Ω)※MNR35	Max. 50mΩ	23±5°C, Immersion cleaning, 5±0.5min Solvent : 2-propanol
Bend strength of the end face plating	± (1.0%+0.05Ω) Without mechanical damage such as breaks.	Max. 50mΩ	—

Compliance Standard(s) : IEC60115-8
JISC 5201-8

●Maximum overload voltage *TEST Voltage

MNR02	MNR04	MNR12	MNR14	MNR15	MNR18	MNR32	MNR34	MNR35
50V	50V	100V	100V	25V	50V	400V	400V	100V

● Tape Dimensions

(Unit : mm)

■ Paper Tape

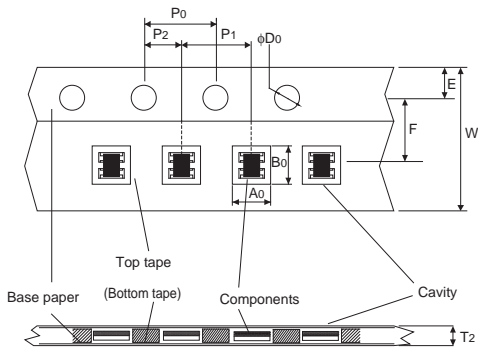

Part No.	Type Code	W	F	E	A0	B0
MNR02	M0AP	8.0±0.3	3.5±0.05	1.75±0.1	1.17±0.1	1.17±0.1
MNR04	M0AP	8.0±0.3	3.5±0.05	1.75±0.1	1.2±0.1	2.2±0.1
MNR12	E0AP	8.0±0.3	3.5±0.05	1.75±0.1	1.8±0.1	1.8±0.1
MNR14	E0AP	8.0±0.3	3.5±0.05	1.75±0.1	1.8±0.1	3.4±0.1
MNR15	E0RP	8.0±0.3	3.5±0.05	1.75±0.1	1.8±0.1	3.4±0.1
MNR18	E0AP	8.0±0.3	3.5±0.05	1.75±0.1	1.95±0.15	4.1±0.15

Part No.	Type Code	D0	P0	P1	P2	T2
MNR02	M0AP	φ1.5 ^{+0.1} ₀	4.0±0.1	2.0±0.1	2.0±0.05	Max 0.5
MNR04	M0AP	φ1.5 ^{+0.1} ₀	4.0±0.1	2.0±0.1	2.0±0.05	Max 1.1
MNR12	E0AP	φ1.5 ^{+0.1} ₀	4.0±0.1	4.0±0.1	2.0±0.05	Max 1.1
MNR14	E0AP	φ1.5 ^{+0.1} ₀	4.0±0.1	4.0±0.1	2.0±0.05	Max 1.1
MNR15	E0RP	φ1.5 ^{+0.1} ₀	4.0±0.1	4.0±0.1	2.0±0.05	Max 1.1
MNR18	E0AP	φ1.5 ^{+0.1} ₀	4.0±0.1	4.0±0.1	2.0±0.05	Max 1.1

■ Embossed Tape

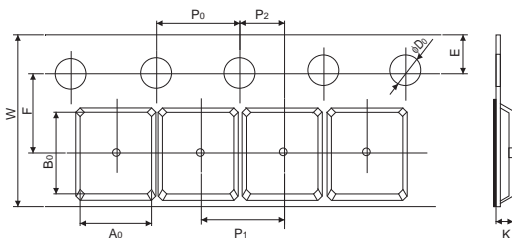

(Unit : mm)

Part No.	Type Code	W	F	E	A0	B0
MNR32	J0AB	8.0±0.3	3.5±0.05	1.75±0.1	3.0±0.1	3.5±0.1
MNR34	J5AB	12.0±0.3	5.5±0.05	1.75±0.1	3.4±0.1	5.6±0.1
MNR35	J5R	12.0±0.3	5.5±0.05	1.75±0.1	3.4±0.1	6.6±0.1

Part No.	Type Code	D0	P0	P1	P2	K
MNR32	J0AB	φ1.5 ^{+0.1} ₀	4.0±0.1	4.0±0.1	2.0±0.05	0.9±0.1
MNR34	J5AB	φ1.5 ^{+0.1} ₀	4.0±0.1	4.0±0.1	2.0±0.05	1.0±0.15
MNR35	J5R	φ1.5 ^{+0.1} ₀	4.0±0.1	4.0±0.1	2.0±0.05	1.0±0.15

●Reel Dimensions

Using two kinds of reels for taping.

① MNR02 / 04 / 12 / 14 / 15 / 18 / 32 / 34 / 35

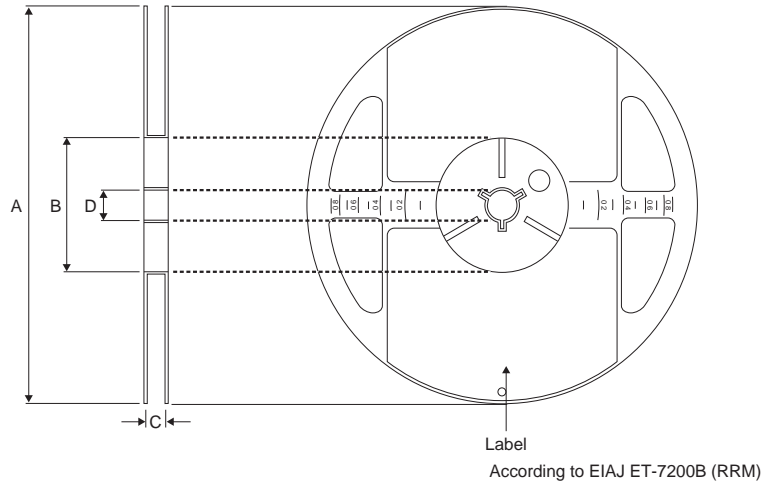

② MNR02 / 04 / 12 / 14 / 15 / 18 / 32

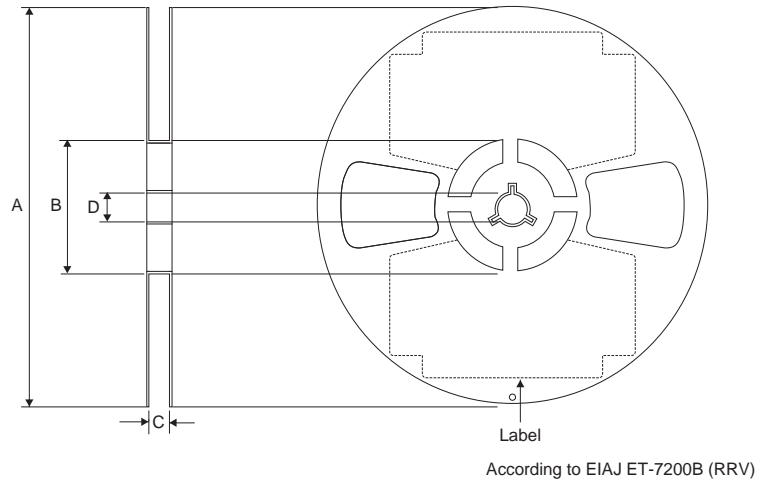

(Unit : mm)

Part No.	Type Code	A	B	C	D
MNR02	M0AP	φ180 ⁰ _{-1.5}	φ60 ^{+1.0} ₀	9 ^{+1.0} ₀	φ13±0.2
MNR04	M0AP				
MNR12	E0AP				
MNR14	E0AP				
MNR15	E0RP				
MNR18	E0AP				
MNR32	J0AB			13 ^{+1.0} ₀	
MNR34	J5AB				
MNR35	J5R				

Notes

- 1) The information contained herein is subject to change without notice.
- 2) Before you use our Products, please contact our sales representative and verify the latest specifications :
- 3) Although ROHM is continuously working to improve product reliability and quality, semiconductors can break down and malfunction due to various factors.
Therefore, in order to prevent personal injury or fire arising from failure, please take safety measures such as complying with the derating characteristics, implementing redundant and fire prevention designs, and utilizing backups and fail-safe procedures. ROHM shall have no responsibility for any damages arising out of the use of our Products beyond the rating specified by ROHM.
- 4) Examples of application circuits, circuit constants and any other information contained herein are provided only to illustrate the standard usage and operations of the Products. The peripheral conditions must be taken into account when designing circuits for mass production.
- 5) The technical information specified herein is intended only to show the typical functions of and examples of application circuits for the Products. ROHM does not grant you, explicitly or implicitly, any license to use or exercise intellectual property or other rights held by ROHM or any other parties. ROHM shall have no responsibility whatsoever for any dispute arising out of the use of such technical information.
- 6) The Products are intended for use in general electronic equipment (i.e. AV/OA devices, communication, consumer systems, gaming/entertainment sets) as well as the applications indicated in this document.
- 7) The Products specified in this document are not designed to be radiation tolerant.
- 8) For use of our Products in applications requiring a high degree of reliability (as exemplified below), please contact and consult with a ROHM representative : transportation equipment (i.e. cars, ships, trains), primary communication equipment, traffic lights, fire/crime prevention, safety equipment, medical systems, servers, solar cells, and power transmission systems.
- 9) Do not use our Products in applications requiring extremely high reliability, such as aerospace equipment, nuclear power control systems, and submarine repeaters.
- 10) ROHM shall have no responsibility for any damages or injury arising from non-compliance with the recommended usage conditions and specifications contained herein.
- 11) ROHM has used reasonable care to ensure the accuracy of the information contained in this document. However, ROHM does not warrants that such information is error-free, and ROHM shall have no responsibility for any damages arising from any inaccuracy or misprint of such information.
- 12) Please use the Products in accordance with any applicable environmental laws and regulations, such as the RoHS Directive. For more details, including RoHS compatibility, please contact a ROHM sales office. ROHM shall have no responsibility for any damages or losses resulting non-compliance with any applicable laws or regulations.
- 13) When providing our Products and technologies contained in this document to other countries, you must abide by the procedures and provisions stipulated in all applicable export laws and regulations, including without limitation the US Export Administration Regulations and the Foreign Exchange and Foreign Trade Act.
- 14) This document, in part or in whole, may not be reprinted or reproduced without prior consent of ROHM.



Thank you for your accessing to ROHM product informations.
More detail product informations and catalogs are available, please contact us.

ROHM Customer Support System

<http://www.rohm.com/contact/>